

Drives@Work

(10 Benefits Adjustable-Speed AC Drives Provide to Industrial Users)

NEW BERLIN, Wis., . . . Adjustable Speed Drives are used in any application in which there is mechanical equipment powered by motors; the drives provide extremely precise electrical motor control, so that motor speeds can be ramped up and down, and maintained, at speeds required; doing so utilizes only the energy required, rather than having a motor run at constant (fixed) speed and utilizing an excess of energy.

Since motors consume a majority of the energy produced, the control of motors, based on demands of loads, increases in importance, as energy supplies become ever more strained. Additionally, end users of motors can realize 25 – 70% energy savings via use of motor controllers. (Despite these benefits, the majority of motors continue to be operated without drives.)

Here are 10 additional benefits users realize when operating motors with drives:

1. Controlled Starting Current - When an AC motor is started "across the line," it takes as much as seven-to-eight times the motor full-load current to start the motor and load. This current flexes the motor windings and generates heat, which will, over time, reduce the longevity of the motor. An Adjustable Speed AC Drive starts a motor at zero frequency and voltage. As the frequency and voltage "build," it "magnetizes" the motor windings, which typically takes 50-70% of the motor full-load current. Additional current above this level is dependent upon the connected load, the acceleration rate and the speed being accelerated, too. The substantially reduced starting current extends the life of the AC motor, when compared to starting across the line. The customer payback is less wear and tear on the motor (motor rewinds), and extended motor life.

2. Reduced Power Line Disturbances - Starting an AC motor across the line, and the subsequent demand for seven-to-eight times the motor full-load current, places an enormous drain on the power distribution system connected to the motor. Typically, the supply voltage sags, with the amplitude of the sag being dependent on the size of the motor and the capacity of the distribution system. These voltage sags can cause sensitive equipment connected on the same distribution system to trip offline due to the low voltage. Items such as computers, sensors, proximity switches, and contactors are voltage sensitive and, when subjected to a large AC motor line started nearby, can drop out. Using an Adjustable Speed AC Drive eliminates this voltage sag, since the motor is started at zero voltage and ramped up.

3. Lower Power Demand on Start - If power is proportional to current-times-voltage, then power needed to start an AC motor across the line is significantly higher than with an Adjustable Speed AC Drive. This is true only at start, since the power to run the motor at load would be equal regardless if it were fixed speed or variable speed. The issue is that some distribution systems are at their limit, and demand factors are placed on industrial customers, which charges them for surges in power that could rob other customers or tax the distribution system during peak periods. These demand factors would not be an issue with an Adjustable Speed AC Drive.

4. Controlled Acceleration - An Adjustable Speed AC Drive starts at zero speed and accelerates smoothly on a customer-adjustable ramp. On the other hand, an AC motor started across the line is a tremendous mechanical shock both for the motor and connected load. This shock will, over time, increase the wear and tear on the connected load, as well as the AC motor. Some applications, such as bottling lines, cannot be started with motors



across the line (with product on the bottling line), but must be started empty to prevent breakage.

5. Adjustable Operating Speed - Use of an Adjustable Speed AC Drive enables optimizing of a process, making changes in a process, allows starting at reduced speed, and allows remote adjustment of speed by programmable controller or process controller.

6. Adjustable Torque Limit - Use of an Adjustable Speed AC Drive can protect machinery from damage, and protect the process or product (because the amount of torque being applied by the motor to the load can be controlled accurately). An example would be a machine jam. With an AC motor connected, the motor will continue to try to rotate until the motor's overload device opens (due to the excessive current being drawn as a result of the heavy load). An Adjustable Speed AC Drive, on the other hand, can be set to limit the amount of torque so the AC motor never exceeds this limit.

7. Controlled Stopping - Just as important as controlled acceleration, controlled stopping can be important to reduce mechanical wear and tear -- due to shocks to the process or loss of product due to breakage.

8. Energy Savings - Centrifugal fan and pump loads operated with an Adjustable Speed AC Drive reduces energy consumption. Centrifugal fans and pumps follow a variable torque load profile, which has horsepower proportional to the cube of speed and torque varying proportional to the square of speed. As such, if the speed of the fan is cut in half, the horsepower needed to run the fan at load is cut by a factor of eight $(1/2)^3 = 1/8$. Using a fixed speed motor would require some type of mechanical throttling device, such as a vane or damper; but the fact remains that the motor would still be running full load and full speed (full power). Energy savings can be sufficient to pay back the capitalized cost in a matter of a couple of years (or less), depending on the size of the motor.

9. Reverse Operation - Using an Adjustable Speed AC Drive eliminates the need for a reversing starter, since the output phases to the motor can be electronically changed without any mechanical devices. The elimination of a reversing starter eliminates its maintenance cost and reduces panel space.

10. Elimination of Mechanical Drive Components - Using an Adjustable Speed AC Drive can eliminate the need for expensive mechanical drive components such as gearboxes. Because the AC Drive can operate with an infinite variable speed, it can deliver the low- or high-speed required by the load, without a speed-increasing or reduction devices between the motor and load. This eliminates maintenance costs, as well as reducing floor-space requirements.

ABB Inc., Automation Technologies, Automation Products, Low-Voltage Drives, is the world's largest manufacturer of electric motors and drives. In the USA, an integrated channel of sales representatives, distributors, and system integrators allow ABB, New Berlin, Wisconsin, to supply a complete line of energy-efficient electric drives, motors and engineered drive systems to a wide range of industrial and commercial customers. Products manufactured include AC and DC variable speed drives for electric motors from 1/8th through 135,000 HP, and application-specific drive system solutions to meet diverse customer needs (<http://www.abb-drives.com>).

ABB (www.abb.com) is a leader in power and automation technologies that enable utility and industry customers to improve performance while lowering environmental impact. The ABB Group of companies operates in around 100 countries and employs about 115,000 people. The company's U.S. operations employ about 9,000 in manufacturing and other facilities in 40 states.

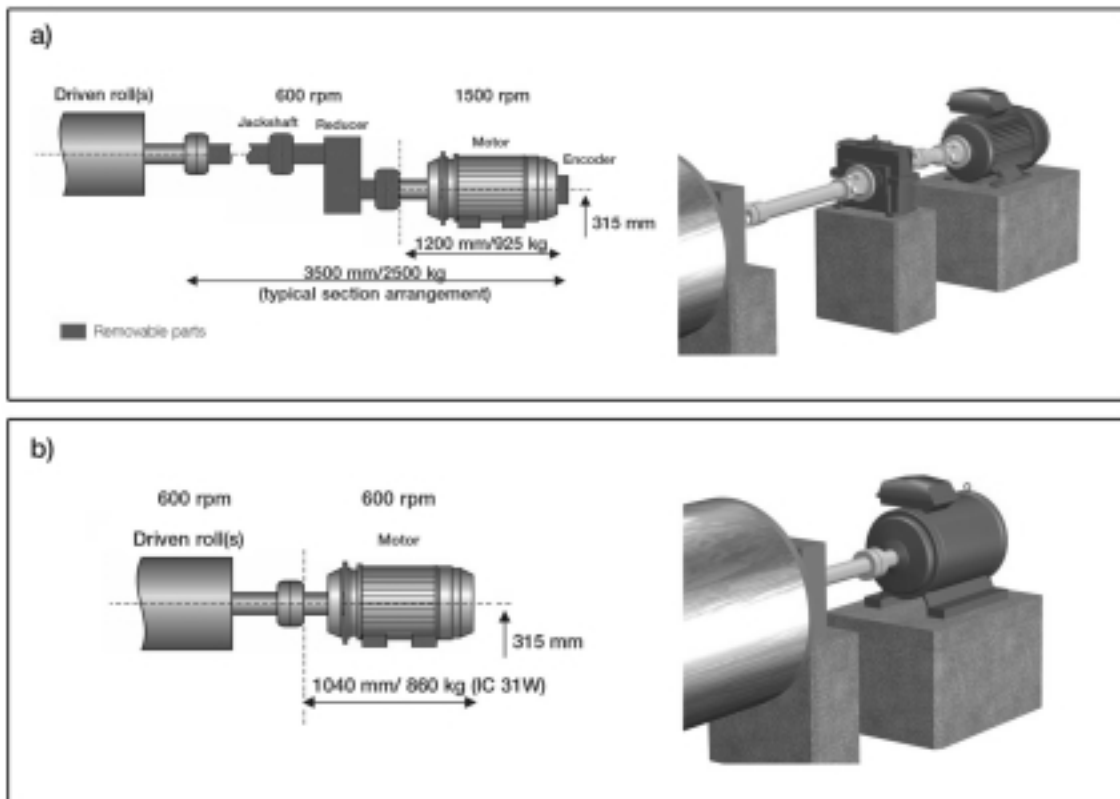

New Berlin, WI . . . Drive configuration with a) conventional induction motor drive, gearbox and jackshaft; and b) a Drive^{IT} Direct Drive Solution

For more information please contact:

ABB Drives
 Mark Kenyon
 262-780-5140 phone
 262-785-8501 fax
mark.kenyon@us.abb.com

ABB Media Relations
 Ken Graber
 262-780-3873 phone
 262-785-8501 fax
ken.j.graber@us.abb.com